



ILAM Stone Ltd
Lydford Road
Meadow Lane
Industrial Estate
Alfreton
Derbyshire DE55 7RQ
Phone: 01773 520088 (general)
Phone 01773 520142 (sales & estimating)
Fax 01773 520077

QUOINS "L" Shaped

DESCRIPTION

A quoin is a corner stone which is "L" Shaped on plan allowing the cavity to remain constant throughout the building

Standard Quoins are 440 by 215 by 215mm high
with 100mm thick wall and a 10mm joints

(For 6mm joints 219 and 294mm high blocks can be supplied)

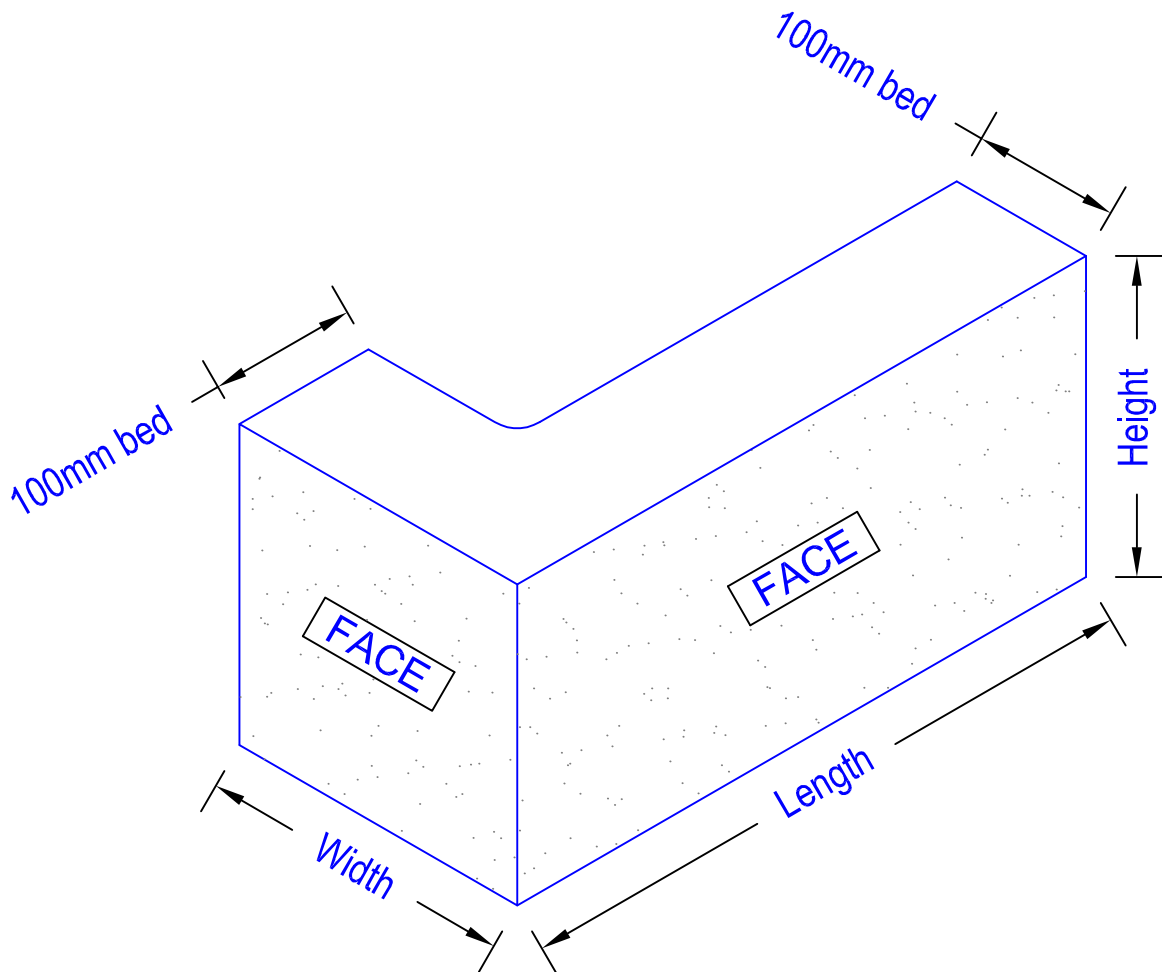

* Other designs can be made to suit customers requirements



ILAM Stone Ltd
 Lydford Road
 Meadow Lane
 Industrial Estate
 Alfreton
 Derbyshire DE55 7RQ
 Phone: 01773 520088 (general)
 Phone 01773 520142 (sales & estimating)
 Fax 01773 520077

QUOINS "L" Shaped

**Plain QUOIN Blocks 100mm on Bed
 for 10mm joints**

| Ref: | Length | Width | Height | Weight approx. |
|------|--------|-------|--------|----------------|
| Q1 | 328 | 215 | 215 | 19.9kg |
| Q2 | 440 | 215 | 215 | 25.5kg |
| Q3 | 440 | 215 | 290 | 34.4kg |

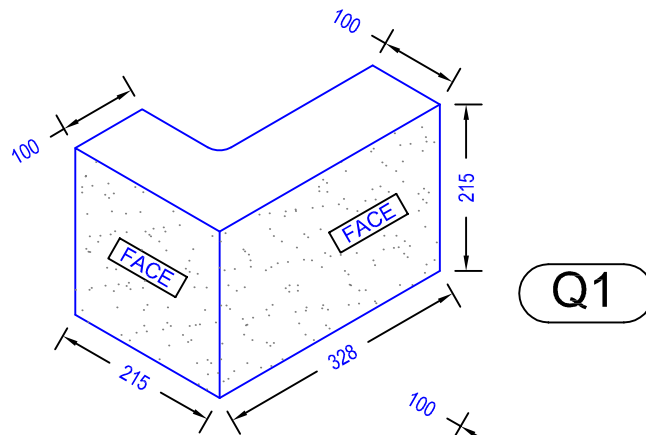

Q1

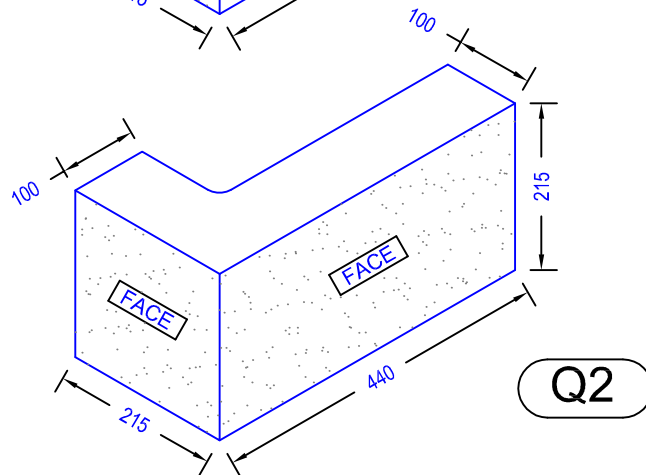

Q2

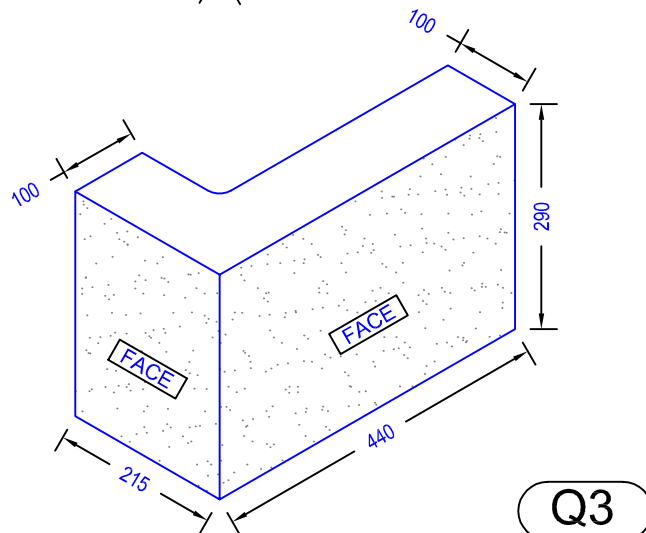

Q3

* Other designs can be made to suit customers requirements



ILAM Stone Ltd
 Lydford Road
 Meadow Lane
 Industrial Estate
 Alfreton
 Derbyshire DE55 7RQ
 Phone: 01773 520088 (general)
 Phone 01773 520142 (sales & estimating)
 Fax 01773 520077

Chamfered QUOINS "L" Shaped

Plain QUOIN Blocks Chamfered 100mm on Bed for 10mm joints

| Ref: | Length | Width | Height | Weight approx. |
|------|---------|---------|--------|----------------|
| Q4 | 328 +18 | 215 +18 | 215 | 25.5kg |
| Q5 | 440 +18 | 215 +18 | 215 | 31.4kg |
| Q6 | 440 +18 | 215 +18 | 290 | 42.4kg |

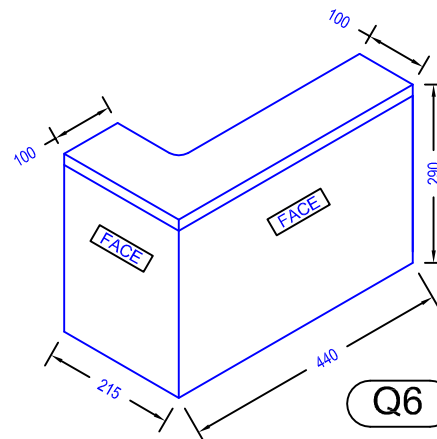
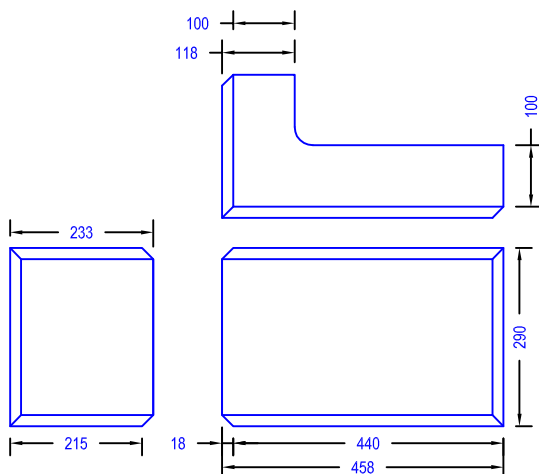
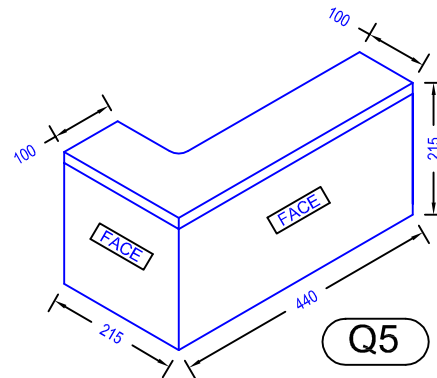
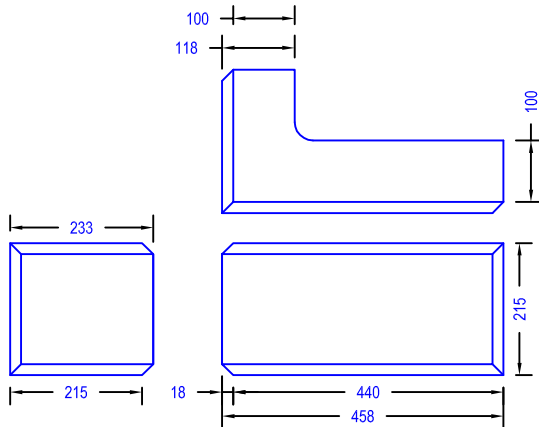
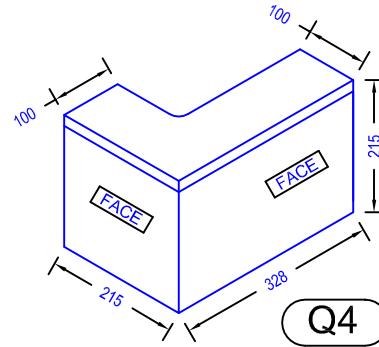
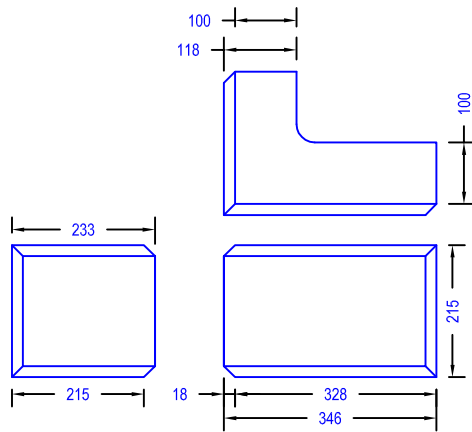

* Other designs can be made to suit customers requirements



ILAM Stone Ltd
Lydford Road
Meadow Lane
Industrial Estate
Alfreton
Derbyshire DE55 7RQ
Phone: 01773 520088 (general)
Phone 01773 520142 (sales & estimating)
Fax 01773 520077

Chamfered QUOINS "L" Shaped

50mm thick for
cladding purposes
also in two pieces

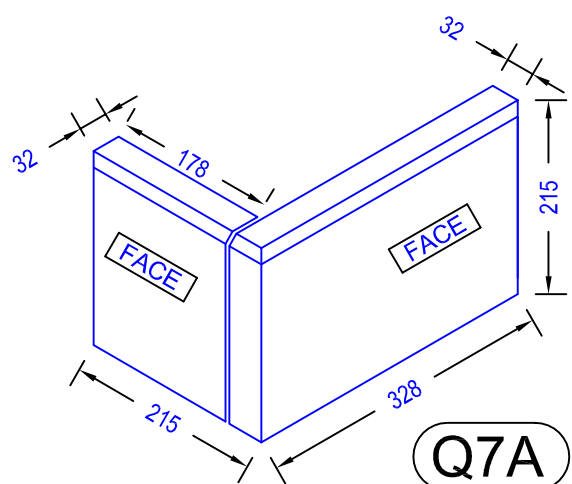
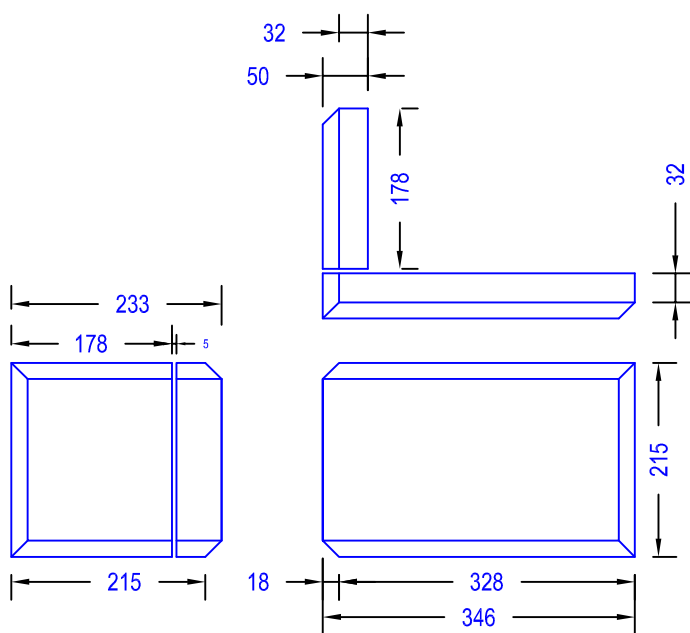
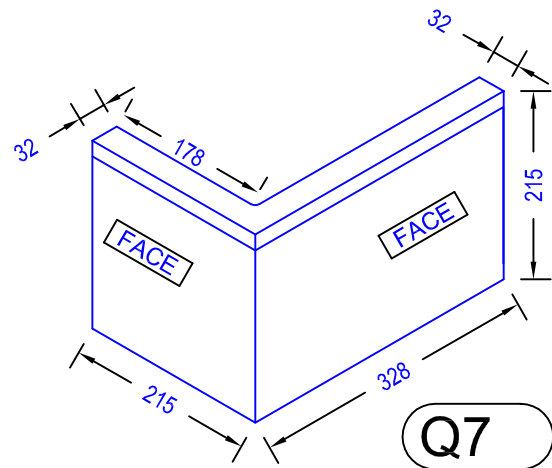
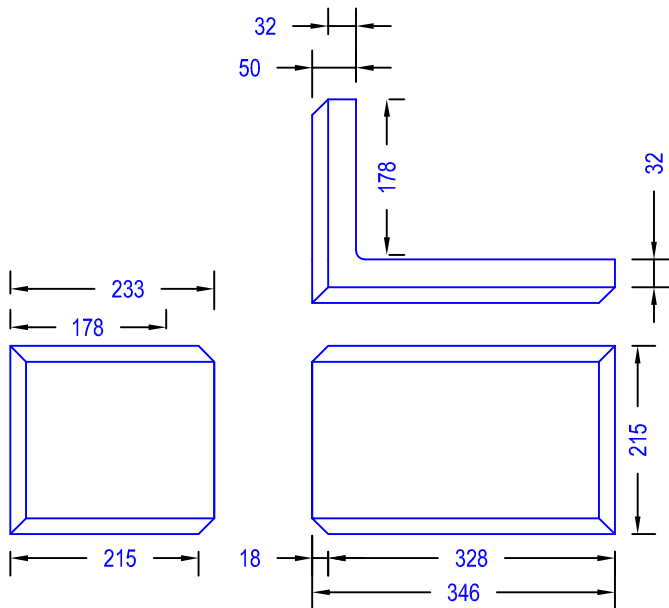

* Other designs can be made to suit customers requirements